

BUFFALO TURBINE LLC

180 Zoar Road
Springville, NY 14141
TEL: 716 592 2700 FAX: 716 592 2460
EMAIL: info@buffaloturbine.com
www.buffaloturbine.com

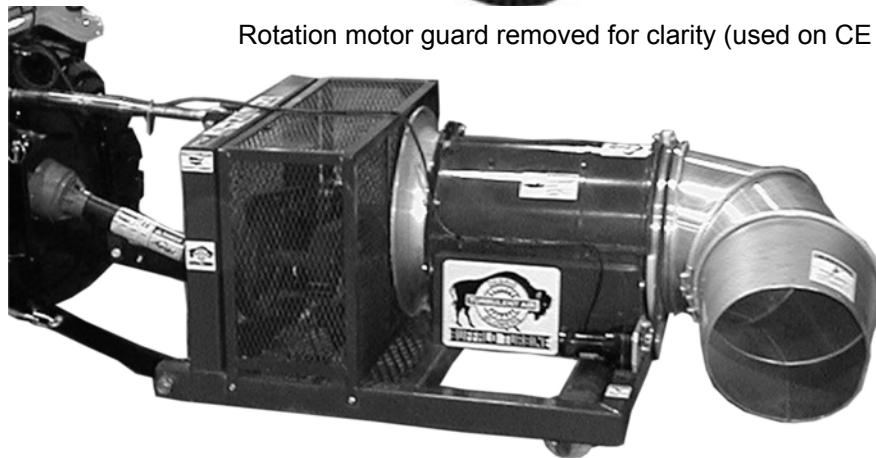

ASSEMBLY INSTRUCTIONS
FOR THE MODEL KB2 IS
ON PAGE 21



Rotation motor guard removed for clarity (used on CE units only)

BUFFALO TURBINE'S MODEL KB2 SERIES and HURRICANE/PTO OPERATOR'S MANUAL AND PARTS BOOK

EC Declaration of Conformity – Page 33

05/05 -BT MAN

BUFFALO TURBINE

WARRANTY REGISTRATION FORM & INSPECTION REPORT

Any units not registered with Buffalo Turbine are not eligible for warranty claims

WARRANTY REGISTRATION

This form must be filled out by the dealer and signed by both the dealer and the customer at the time of delivery

Customer's Name _____ Dealer's Name _____

Address _____ Address _____

City, State, Zip, Country _____ City, State, Zip, Country _____

Email Address (important) _____ Email Address _____

Telephone Number _____

Blower Model _____

Circle one:

Serial Number _____

Commercial Use

Delivery Date _____

Private Use

DEALER INSPECTION REPORT

SAFETY CHECKS

_____ Tire Pressure Check -- Model KB

_____ All Decals Installed

_____ Wheel Bolts

_____ Review Operating and

_____ Belt Tension

Safety Instructions

_____ Lubricate Machine

_____ Guards in Place

_____ Fasteners Tight

_____ Trailer assembly bolts properly installed and tightened

ALL 3 POINT HITCH MODELS: PTO SHAFTS MUST TELESCOPE IN EVERY POSITION

I have thoroughly instructed the buyer on the above described equipment which review the included Operator's Manual content, equipment care, adjustments, safe operation and applicable warranty policy.

Date _____ Dealer's Rep. Signature _____

The above equipment and Operator's Manual has been received by me and I have been thoroughly instructed as to the care, adjustments, safe operation and applicable warranty policy.

Date _____ Owner's Signature _____

PLEASE FAX A COPY TO BUFFALO TURBINE AT 716 592 2460

SERIAL NUMBER LOCATION

Always give your dealer the serial number of your Debris Blower when ordering parts or requesting service or other information.

The serial number plate(s) is located where indicated in the pictures below. Please document the number in the space provided for easy reference.

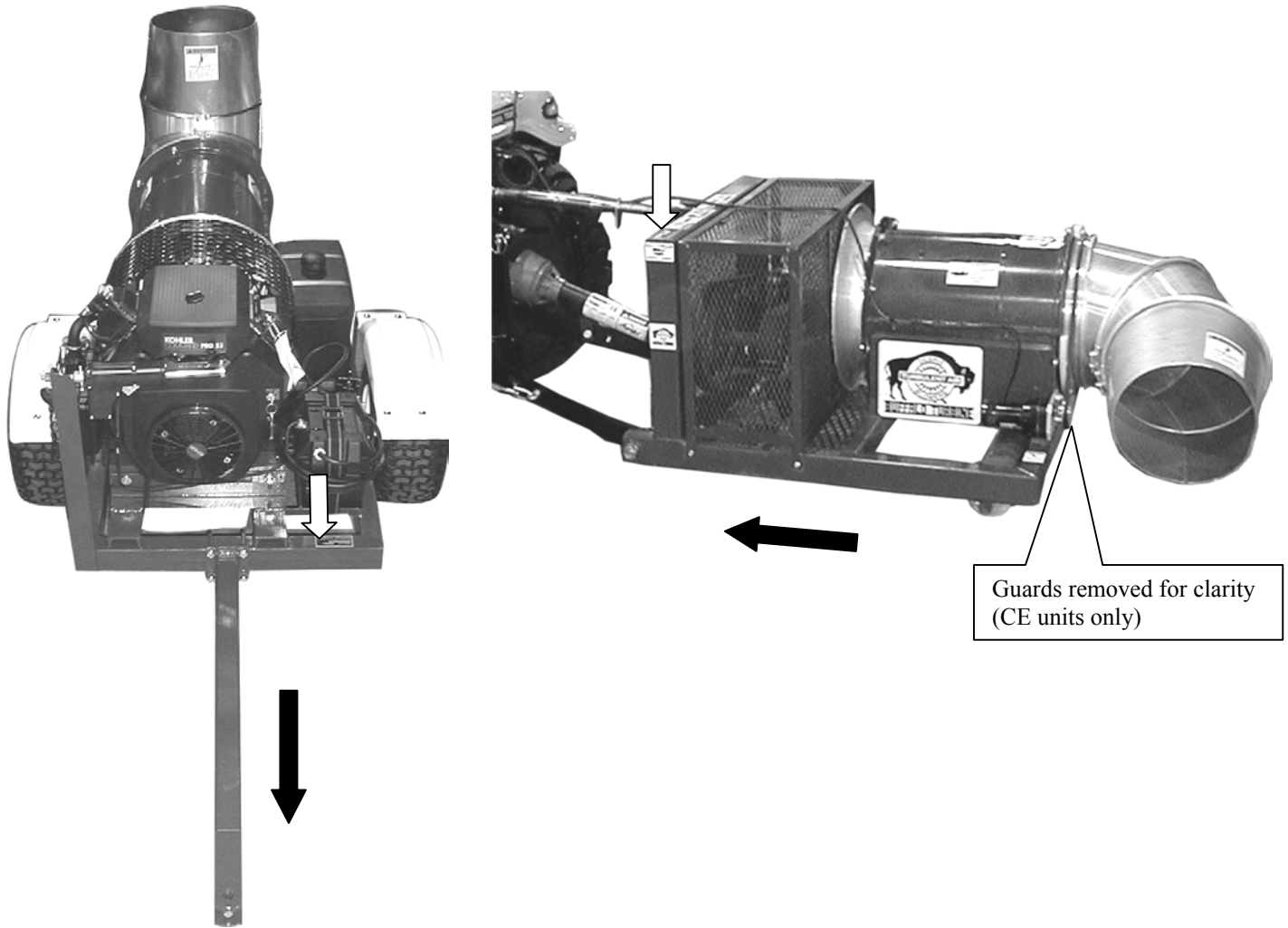

THE DIRECTION OF TRAVEL DETERMINES THE FRONT OR REAR OF BLOWER UNITS

Model KB2

LEFT FRONT TOP SURFACE OF FRAME

Serial Number _____

Hurricane/PTO

UPPER TOP LEFT FRONT OF FRAME

Serial Number _____

BUFFALO TURBINE DEBRIS BLOWERS

WARRANTY

Buffalo Turbine LLC, Inc. warrants the DEBRIS BLOWER to be free from defects in material and workmanship, under normal use and service. Obligation under this warranty shall extend for a period of 1 year (12 months) and shall be limited to, at the option of Buffalo Turbine, replacement of any parts found, upon inspection by Buffalo Turbine, to be defective.

Buffalo Turbine reserves the right to incorporate improvements in material and design of its products without notice and is not obligated to make the same improvements to equipment previously manufactured.

WARRANTY CLAIMS

The purchaser claiming under this warranty shall submit a warranty claim in the prescribed form to Buffalo Turbine or an Authorized Dealer, for inspection by an authorized company representative.

Factory ordered Buffalo Turbine parts must be used when filing a warranty claim.

LIMITATIONS OF LIABILITY

This warranty is expressly in lieu of all other warranties expressed or implied and all other obligations or liabilities on our part of any kind or character, including liabilities for alleged representations or negligence. We neither assume nor authorize any other person to assume on our behalf, any liability in connection with the subsequent sale of the **DEBRIS BLOWER**.

This warranty shall not apply to any DEBRIS BLOWER, which has been altered outside the factory in any way so as, in the judgement of Buffalo Turbine, to affect its operation or reliability, or which has been subject to misuse, neglect, or accident.

This warranty does not cover parts and accessories, which are under separate guarantee from the manufacturers and service can be, obtained from their service facilities. No warranty is extended to regular service items such as lubricants, belts, paint and the like.

OPERATION MANUAL

The Purchaser acknowledges having receiving training in the safe operation of the DEBRIS BLOWER and further acknowledges that Buffalo Turbine does not assume any liability resulting from the operation of the DEBRIS BLOWER in any manner other than described in the Operator's Manual supplied at the time of purchase.

WARRANTY VOID IF NOT RESGISTERED

If there are any questions regarding any of our products call Buffalo Turbine at 716 592 2700.

DO NOT SPLIT THE TURBINE HOUSING FOR ANY REASON.

DO NOT ATTEMPT TO SERVICE OR DISASSEMBLE THE TURBINE BLOWER.

DO NOT USE THE TOP OF THE TURBINE HOUSING TO STRAP OR TIE DOWN BLOWER UNITS.

Unauthorized service work on the Turbine Blower will null and void all warranties.

1. INTRODUCTION

Congratulations on your choice of a Buffalo Turbine Debris Blower. This equipment has been designed and manufactured to meet the needs of a discerning Turf Care Industry.

Safe, efficient and trouble-free operation of your Buffalo Turbine Blower requires that you and anyone else who will be operating or maintaining the Blower, read and understand all of the safety, operation, maintenance and trouble shooting information contained within this Operator's manual.

This Manual covers the Hurricane/PTO and the Model KB2 Series.

Keep this manual handy for frequent reference and to pass on to new operators or owners. Call your Buffalo Turbine dealer or distributor if you need assistance, information, or additional copies of the manuals.

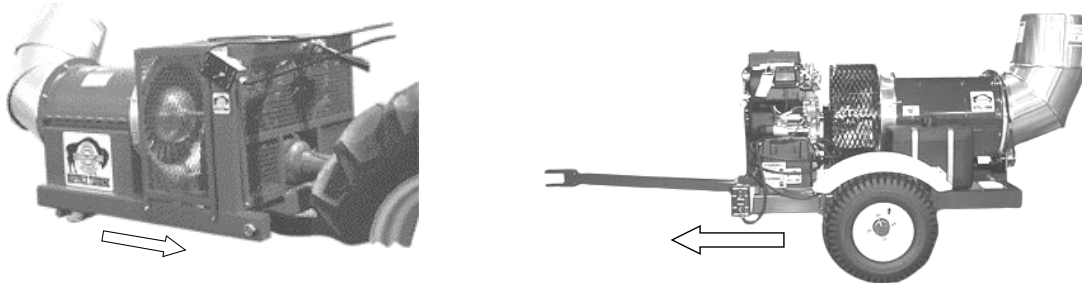

OPERATOR ORIENTATION – The directions left, right, front and rear, as mentioned throughout the manual, are as seen from the driver's seat and facing in the direction of travel.

2 SAFETY

SAFETY ALERT SYMBOL

This safety Alert symbol means **ATTENTION! BECOME ALERT! YOUR SAFETY IS INVOLVED!**

The Safety Alert symbol identifies important safety messages on the Buffalo Turbine Blower and in the manual. When you see this symbol, be alert to the possibility of personal injury or death. Follow the instructions in the safety message.

Why is **SAFETY** important to you?



**3 Big Reasons: Accidents Disable and Kill
Accidents Cost
Accidents Can Be Avoided**

SIGNAL WORDS: Note the use of the signal words **DANGER**, **WARNING** and **CAUTION** with the safety messages. The appropriate signal word for each message has been selected using the following guidelines:

1. **DANGER** – An immediate and specific hazard that **WILL** result in severe personal injury or death if the proper precautions are not taken.
2. **WARNING** -- A specific hazard or unsafe practice that **COULD** result in severe personal injury or death if proper precautions are not taken.
3. **CAUTION** – Unsafe practices that **COULD** result in personal injury if proper practices are not taken, or as a reminder of good safety.

2. SAFETY

YOU are responsible for the **SAFE** operation and maintenance of your Buffalo Turbine Debris Blower. **YOU** must ensure that you and anyone else who is going to operate, maintain or work around the Buffalo Turbine Blower be familiar with the operating and maintenance procedures and related **SAFETY** information contained in this manual. This manual will take you step-by-step through your working day and alerts you to all good safety practice while operating the Blower.

Remember **YOU** are the key to safety. Good safety practices not only protect you but also the people around you. Make these practices a working part of your safety program. Be certain that **EVERYONE** operating this machine is familiar with the procedures recommended and follows safety precautions. Remember most accidents can be prevented. Do not risk injury or death by ignoring good safety practices.

- Blower owners must give operating instructions to operators or employees before allowing them to operate the Blower, and at least annually thereafter.
- The most important safety device on this equipment is a **SAFE** operator. It is the operator's responsibility to read and understand ALL Safety and Operating instructions in the manual and to follow these. All accidents can be avoided.
- A person who has not read and understood all operating instructions is not qualified to operate the machine. An untrained operator exposes themselves and bystanders to possible serious injury or death.
- Do not modify the equipment in any way. Unauthorized modification may impair the function and/or safety which could affect the life of the equipment.
- Think **SAFETY!** Work **SAFELY!**

2.1 GENERAL SAFETY

1. Read and understand the Operator's Manual and all safety signs before operating, maintaining, and adjusting.
2. Provide a first-aid kit for use in case of an accident. Store in a highly visible place.
3. Provide a fire extinguisher for use in case of an accident. Store in a highly visible place.
4. Wear appropriate protective gear. This list includes but is not limited to:
 - A hard hat
 - Protective shoes with slip resistant soles
 - Protective glasses or goggles
 - Heavy gloves
 - Wet weather gear
 - Hearing protection
5. Do not operate without guards or shields properly installed.
6. Do not allow riders.
7. **Wear appropriate ear protection for prolonged exposure to excessive noise.**
8. **(All Models) Set Blower on the ground, disengage PTO, stop engine, set park brake, remove ignition key and wait for all moving parts to stop before dismounting to service or adjust.**
9. Clear the area of people, especially small children, before starting the unit.
10. Review all safety related items annually with all personnel who will be operating or maintaining the Blower.
11. Keep hands, feet, hair and clothing away from moving parts.
12. Operate equipment only while seated in the operator's seat.

2.2 OPERATING SAFETY

1. Read and understand the Operator's Manual and all safety signs before operating, servicing or adjusting.
2. Before servicing or repairing the Model KB2 Series, **Turn Off Engine, remove key and Disconnect Battery Terminals.**

MAINTENANCE SAFETY

1. Read and follow ALL general, operating, maintenance and safety information in this manual.
2. Support the machine with blocks or safety stands when changing tires or working beneath it.
3. (All Models) Set Blower on the ground, disengage PTO, stop engine, set park brake, remove ignition key and wait for all moving parts to stop before operating, servicing or adjusting.
4. Do not adjust the drive belt when it is rotating.
5. Make sure all guards are in place and properly secured when operating or maintaining the Blower.

2.4 TRANSPORT SAFETY

1. Make sure you are in compliant with all local DOT regulations regarding transporting Buffalo Turbine equipment on public roads and highways. DOT APPROVED TRAILERS ARE AVAILABLE FROM BUFFALO TURBINE.
2. **ALL SKID MOUNTED UNITS MUST BE SECURELY ANCHORED TO THE VEHICLE BEING USED BEFORE TRANSPORTING OR OPERATING.**

2.5 STORAGE SAFETY

1. Store the Blower on a firm, level surface.
2. Store away from areas of human activity. Do not permit children to play on or around the stored machine.
3. Make sure the unit is sitting, or blocked up firm and solid and will not tip or sink into a soft area.
4. Cover with a weatherproof tarpaulin and tie down securely.

2.6 TIRE SAFETY (Model KB Series)

1. Do not attempt to mount a tire unless you have the proper equipment and experience to do the job.
2. Have a qualified tire dealer or repair service perform required tire maintenance.

2.7 SAFETY DECALS

Keep safety decals and signs clean and legible at all time.

1. Replace safety decals and signs that are missing or have become illegible.
2. Replaced parts that displayed a safety sign should also display the current sign.
3. Safety decals or signs are available from your Dealer Parts Department.

3. SAFETY DECAL LOCATIONS

The types of decals on the blower units are shown below. For locations of each label, see parts reference in back of this manual.

Good safety requires that you familiarize yourself with the various Safety Decal's, the type of warning and the area, or particular function related to that area that requires your SAFETY AWARENESS.

• Think SAFETY! Work SAFETY!

! ATTENTION !

1. KEEP HANDS, FEET AND CLOTHING AWAY FROM POWER DRIVEN PARTS.
2. STOP ENGINE AND REMOVE KEY BEFORE LEAVING OPERATORS POSITION.
3. MACHINE MUST COME TO A COMPLETE STOP BEFORE ANY MAINTENANCE, TO INCLUDE ADJUSTING, LUBRICATING OR CLEANING, IS PERFORMED.
4. KEEP PEOPLE AND PETS AT SAFE DISTANCE FROM MACHINE.
5. KEEP ALL GUARDS AND SHIELDS IN PLACE.

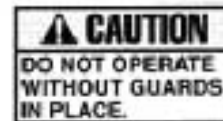

NOTE: All decals are at 50% of actual size

REMEMBER - If Safety Decal's have been damaged, removed, become illegible or parts replaced without decal's, new decal's must be applied. New decal's are available from your authorized dealer.

4. OPERATIONS

4.1 TO THE NEW OPERATOR OR OWNER

Buffalo Turbine Debris Blowers are designed to quickly and efficiently, blow away leaves, cuttings and other debris. The material is conveyed on a stream of high volume and velocity of air to remove it from the area of concern. When the material is removed, it gives a neat, professional look to the working area.

Many of the features incorporated into the machine are the result of suggestions made by customers like you. Read the manual carefully to learn to operate the machine safely and how to set it to provide maximum efficiency. The manual will take you step-by-step through your working day. By following the operating instructions in conjunction with a good maintenance program, your Blower will provide many years of trouble-free service.

4.2 BREAK-IN

Although there are no operational restrictions on the Blower when it is used for the first time, it is recommended that the following mechanical items be checked:

- A. Operating for first ½ hour
 - 1. Re-torque all wheel bolts, axle nuts and trailer mounting bolts and nuts. (Model KB2 Series)
 - 2. Re-torque all other fasteners and hardware.
 - 3. **Check that the drive line shield turns freely on the shaft and that it can telescope easily without BOTTOMING OUT. (PTO Models)**

- B. Operating for first 5 hours
 - 1. Re-torque all hardware and fasteners.
 - 2. Check the tension of the input drive belt. Adjust as required.
 - 3. Go to the normal servicing and maintenance schedule as defined in the Maintenance Section of the manual.

4.3 PRE-OPERATION CHECKLIST

Efficient and safe operation of the Buffalo Turbine Blower requires that each operator reads and understands the operating procedures and all related safety precautions outlined in this section. A pre-operation checklist is provided for the operator. It is important for both personal safety and maintaining the good mechanical condition of the machine that this checklist is followed.

Hurricane/PTO

Before operating the Blower and each time thereafter, the following areas should be checked off:

1. Lubricate the machine per the schedule outlined in the "Maintenance Section"
2. Use only with the power unit appropriate for the design of the machine.
3. Ensure that the machine is properly attached to the power unit attaching arms and that the mounting pins are secured in position.
4. Ensure that the PTO driveline is securely attached on both ends and can telescope easily.
5. Check that the PTO driveline shield rotates freely.
6. Check the belts and pulleys for proper tension and alignment. Adjust as required.
7. Ensure that all bearings turn freely.
8. Make sure all guards and shields are in place, secured and functioning as designed.

PTO DRIVE LINE

Use only the PTO Driveshaft supplied with the Buffalo Turbine Debris Blower. (Hurricane/PTO). The overall length of the PTO Shaft is 30".

THE PTO SHAFT MUST TELESCOPE !!!

CHECK THE LENGTH FROM THE INPUT SHAFT OF THE BLOWER UNIT TO THE POWER TAKE OFF SHAFT OF THE TRACTOR BEFORE ATTEMPTING TO OPERATE. DO NOT ATTEMPT TO MODIFY PTO SHAFT !!!!!

4.3 PRE-OPERATION (CONTINUED) / MODEL KB2 Series

BATTERY MUST BE CONNECTED BEFORE OPERATION. (DISCONNECTED FOR SHIPPING).

Before Operating the Blower and each time thereafter, the following areas should be checked off.

1. For fuel, oil, and operating information of the Kohler or Honda Engine, refer to the Manufacturers specs included with this manual.
2. The Model KB2 turf trailer is not designed for highway towing. For highway use or speeds above 15 mph (24k) an optional DOT approved trailer must be used.
3. Insure the Blower unit is attached to a proper receiver mounted on the towing vehicle. A pin hitch receptacle is standard with the Model KB2 Series. **Attach the KB trailer using the proper size hitch pin with a locking presto pin.**
4. Make sure all guards and shields are in place, secured and functioning as designed.

Remote Throttle Control

The control box contains 2 toggle or rocker switches for the remote nozzle and throttle control kits. The momentary toggle or rocker switch will shut off the power when it is released. The throttle control adjusts the engine RPM from an idle to maximum RPM and the nozzle control adjusts the rotation of the nozzle assembly (360° in either direction).

4.5 ATTACHING THE BLOWER TO THE TRACTOR (Hurricane/PTO)

Follow this procedure when attaching the Hurricane PTO Blower to a tractor:

1. Clear the area of bystanders, especially small children.
2. Make sure the tractor has proper HP and is in good working order, including 3PT hitch, PTO out put shaft, and safety equipment.
3. Make sure there is enough room and clearance from obstacles to safely back up to the Blower. Align 3PT hitch lift pins to match tractors. Lower lift pins may have to be positioned either inside or outside of frame depending on the width of the tractor's 3PT hitch arms. Tighten lift pins securely.
4. Back up to the Blower--attach lower lift pins to lower lift arms of the tractor. Insert retainers. Now attach upper or top link using the mounting pin provided. Insert retainer pin.
5. Adjust top link so Blower unit is level to the ground.
6. Install PTO shaft. Ensure that the PTO driveline is securely attached on both ends and can telescope easily every position. Check that the PTO driveline shield rotates freely. Install and tighten clamping bolt from PTO shaft to blower unit input shaft (early models) or insure that both spring loaded locking pins are locked and in proper position on both splined shafts. Never attempt to maintain or attach PTO shaft while tractor is running!
7. To unhook the Blower unit from the tractor, reverse the above procedure. Always park the Blower unit and tractor in a dry, level area.
8. **Hurricane/PTO with electric remote nozzle kit:** Connect the remote nozzle control to a 12- volt system only.
9. **The built in rear roller** is used when the blower unit is operated close to the ground or on hilly terrain.

4.5 (continued) Model KB2 Series

Turf Trailer assembly instructions for the BT-KB10G2

1. Attach 2 axle mounts (Part # 1713) with 2 bolts each (Part # 1137), do not tighten at this time.
2. Attach axle (Part # 1407) to axle mounts using 2 bolts, do not tighten at this time.
3. Tighten 4 axle mount bolts and the 2 bolts holding the axle. Use ½-13 Nyloc nuts (part # 1180).
4. Attach the trailer tongue (part # 1490) using 2 U-bolts (part # 1707).
5. Attach both fenders (part # 1150) using (4) 3/8-16 x 1" carriage bolts (part # 1154) and (4) 3/8-16 hex nuts for each fender.
6. Recheck the trailer mounting bolts to assure they are tightened securely.
7. Bolt on tires and rims.
8. Attach battery terminals.

USE PRESTO PIN TO KEEP HITCH PIN IN PLACE WHILE OPERATING

4.6 FIELD OPERATION

OPERATION SAFETY –

Do not direct debris blower towards people, pets, autos, windows, etc.

4.7 Starting Blower Unit / (Hurricane/PTO)

Engage the tractor PTO control at a low idle engine speed.

Stopping the Blower Unit

- a. Gradually slow the tractor RPM down to low idle using the throttle
- b. Slowly disengage or switch off the PTO clutch and allow the blower fan to come to a stop. Place PTO control into the neutral lock position.

4.9 Operating RPM (Both Models)

The tractor manufacture normally recommends that the unit always be run at maximum RPM or wide open throttle. This recommendation is made to insure efficient attachment operation and hydrostatic drive function. The Blower can operate at a slower RPM if it can effectively move the debris material. Vary ground speed with the hydrostatic transmission. Increase engine RPM to improve tractor efficiency.

Moving light material, such as dry leaves, requires less wind than wet or heavier material.

Always try to blow with the wind. The Blower can be used for a wide variety of applications to move leaves, grass clippings, aeration plugs and debris. Drying wet areas has been another use with these powerful Debris Blowers.

1. PTO Models and Model KB2 Series Electric Remote Nozzle controls: (12v system)

Moving the toggle or rocker switch in either direction on the hand held control box changes the air stream direction. The nozzle will stop turning by releasing the toggle or rocker switch. **USE CAUTION WHEN OPERATING THE NOZZLE IN THE DOWN POSITION DUE TO MINIMAL GROUND CLEARANCE (360 degree rotation)**
NOTE: Make sure the cable is clear of all moving parts including the PTO shaft.

CAUTION ! DO NOT ALLOW LEAVES OR DEBRIS TO ACCUMULATE ON OR NEAR THE ENGINE OR EXHAUST SYSTEM OF THE MODEL KB2 BLOWER, TRACTOR ENGINE OR ANY INTERNAL COMBUSTION ENGINE.

5. TRANSPORTING

PTO Unit (attached to tractor)

1. Raise the lift arms.
2. Do not run the PTO Blowers when raised to its maximum height. At the raised or highest position, the driveline angles are severe and can cause machine vibration and damage.
3. It is not recommended that the machine be transported faster than 15 mph (24 k). Slow down for corners or rough roads and terrain. Always retain control of the vehicle.

5.1- Transporting the Model KB2 Series

1. **Turf Trailer Receptacle Uses A Pin Hitch Only. Use Presto Pin. Do Not Exceed 15 MPH (24 k) At Any Time. Use a DOT approved trailer for Highway Use and for speeds exceeding 15 MPH (24 k).**

2. The Skid Model KB2 can easily be transported and operated in the bed of a standard pick-up truck or utility vehicle. Be sure to block, anchor and secure the unit before operating or transporting. **Do not use the top of the Turbine housing to strap or tie down blower unit.**

5.2 STORAGE

At the end of the working season or before storing the blower unit, prepare the machine by following this procedure:

1. Select a storage area that is dry, level and free of debris.
2. Thoroughly wash the machine with a water hose to remove all debris and residue.
3. Lubricate all grease fittings with one shot of grease to displace any accumulated water.
4. Run the machine at low RPM to dry the Blower Components.

5. Unhook the tractor (See section 4.6).
6. Remove the free portion of the PTO drive line and store in a safe place.
7. Apply a fresh coat of grease to the telescoping portion of the shaft to prevent rusting.
8. Touch up all paint chips and scratches to prevent rusting.
9. Inspect for worn or failed components. Order the replacement parts and repair the blower unit when time allows. This will eliminate unnecessary down time at the start of next season.
10. Store in an enclosed building. If space is not available, cover with a waterproof tarpaulin and tie it down securely.
11. Store the machine away from areas of human activity.
12. Do not allow children to play around the stored unit.

Model KB2 Series:

Wash Blower unit, then run at lower rpm's to dry blower and engine. Change oil per manufacturer's specs (see engine owner's manual section). If necessary, spray a Teflon lubricant in the nozzle base groove to insure freer rotation. Park and block unit so the tires clear the ground.

5.3 SERVICE & MAINTENANCE

! MAINTENANCE SAFETY !

1. Set Blower on a level surface, disengage PTO, stop engine, set park brake, remove ignition key and wait for all moving parts to stop before dismounting to service, adjust or repair.
2. Reinstall and secure all shields removed for servicing before starting to use machine again.
3. Securely support machine with blocks or safety stands when changing tires or working beneath it.

SERVICE

5.4.1 FLUIDS & MAINTENANCE

Grease (Hurricane/PTO)

Use SAE multi-purpose high temperature grease for all applications. SAE multi-purpose lithium base grease is also acceptable. If necessary use a Teflon spray lubricant only on the nozzle base and slides provides for freer rotation.

USE ONLY CLEAN LUBRICANTS

Model KB2 Series: Change oil per Manufacturer's specification (see engine owner's manual section). A Teflon spray type lubricant on the nozzle base and slides provides for freer rotation.

5.6 Servicing Interval

Grease all fittings on your new equipment after the first 8 hours of operation.

THE PTO SHAFT MUST TELESCOPE IN EVERY POSITION!!! CHECK THE OVERALL LENGTH BEFORE OPERATION. DAMAGE TO THE DRIVE SYSTEM OF THE DEBRIS BLOWER WILL OCCUR WITHOUT PROPER CLEARANCE AND LUBRICATION !!!!!!!

PTO SHAFT LUBRICATION

40 Hours

1. PTO drive line greasing- See photo



2. 5 pillow blocks- approx. 2 shots of grease. Use a grease gun extension. **The holes in the top of the guard line up with the pillow block grease fittings. Removal of guards is not necessary to grease pillow blocks.** (See page 16)

3. **DO NOT OVER GREASE**

4. Periodic Teflon spray lubricant on the elbow base and slides will assure smooth operation of nozzle.

5.7 SERVICE RECORD

See Lubrication and Maintenance sections for details of service. Copy this page to continue record.

TURN OFF, REMOVE KEY & DISCONNECT BATTERY BEFORE SERVICING BLOWER UNIT REMOVE PTO SHAFT ON THE HURRICANE AND FRONT MOUNT UNITS

CODE: LUBRICATE-(L) / CHECK-(*) / CHANGE-(C) / REPLACE-(B) / CLEAN-(CL)

SCHEDULED MAINTENANCE HOURS _____

SERVICED BY _____

MAINTENANCE

8 hrs or daily

ALL UNITS – Remove all debris that has settled between the blower wheel fan and the stationary vanes. Helps maintain peak performance.

(L) PTO Drive line greasing (new blower unit)

20 hours

(L) PTO Drive line greasing

40 hours

(L) PTO Drive line greasing

(L) Pillow block and flange bearing greasing (5)

(L) Driveshaft bearings (2)

(*) Check condition of coupling (center section # 1256) and connecting bolts and nuts. (see page 24)

(L) Nozzle base slides(Teflon spray)

(*) Belt tension- SEE SECTION 5.2.1.

(*) Wash and Clean any dirt or grime build up that has accumulated on blower wheel fan blades. Helps to minimize vibration balance and maintain peak performance.

200hrs or annually

(CL) Machine

(CL) &(L) Driveline shield

DO NOT OPERATE BLOWER UNIT WITHOUT GUARDS SECURELY ATTACHED

MAINTENANCE

5.8 BELT TENSION

Efficient machine operation requires that the belts always be properly tensioned. To adjust the belt tension, follow this procedure:

1. Disengage PTO, shut off tractor, remove key and disconnect PTO shaft before removing guards.
1. The flange bearing (1) is fixed and pinned. This will be your starting point for belt adjustment. Do not loosen the bolts on the flange bearing unless you are planning on replacing this bearing.
2. Loosen pillow block bearings 2 and 3 (2 bolts each). Leave a slight tension on the bearing bolts. This will prevent unnecessary movement. Loosen the lock nuts on each of the adjustment screws. These are located at the base of the bearings. Turn both adjustment screws equally to achieve proper tension on belt # 6. Securely tighten both bolts on pillow block bearings 2 & 3. Tighten lock nuts on adjustment screws. Check pulley alignment with a straight edge and re-check belt tension.
3. Repeat this procedure for the adjustment of input belt #7. The pillow block bearings 4 and 5 are used to adjust belt #7. Check pulley alignments and belt tension when completed.
4. If there's proper belt tension and pulley alignment, install the safety guards, start tractor and engage PTO. Visually check for any belt slippage or misalignment.

TENSION SPECS FOR BELT # 3/5VX500

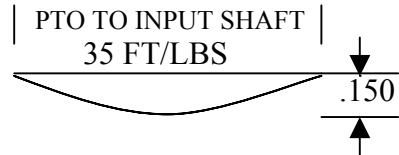

TENSION SPECS FOR BELT # 3/3VX500

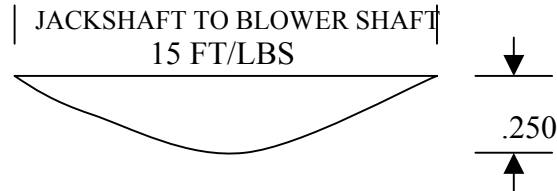

 Designates grease-fitting location. **GUARDS REMOVED FOR CLARITY**

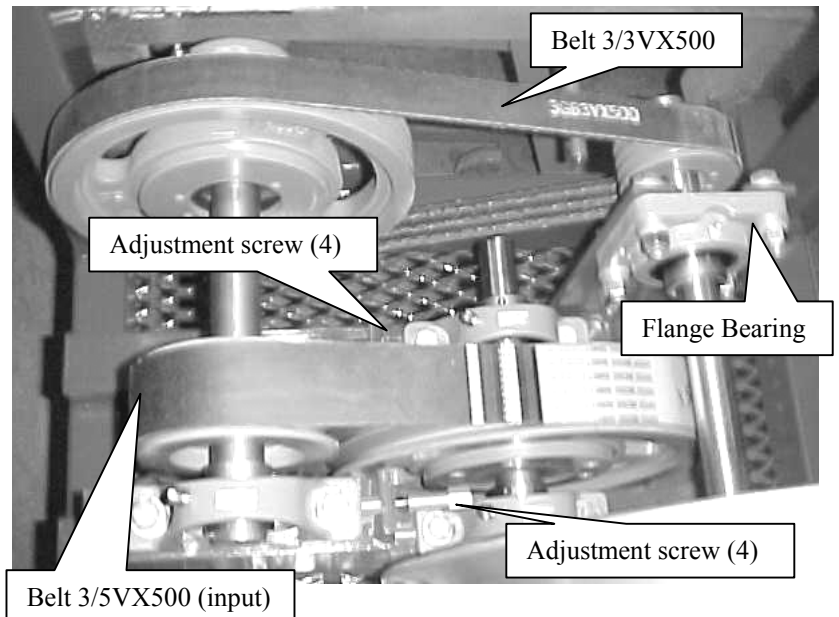
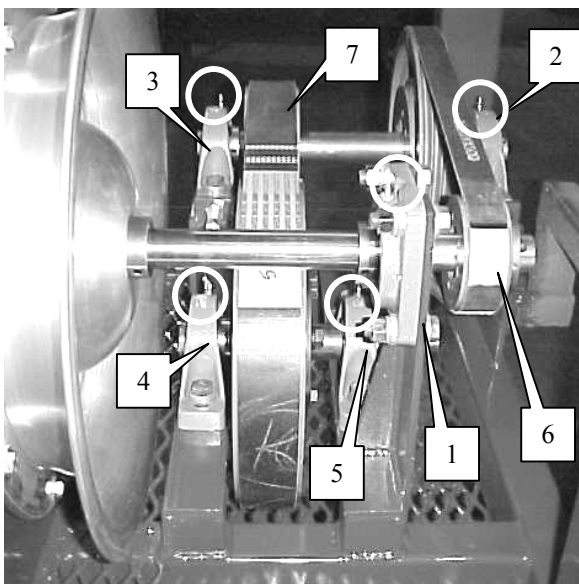

5.9 CHANGING THE BELTS

USE THE ILLUSTRATION FROM THE PREVIOUS PAGE FOR REFERENCE

After using the Blower unit for a long period of time, the belts will stretch and wear. To change the belts follow this procedure:

1. Lower the blower unit on to secure stands or wooden blocks, disengage PTO clutch, stop engine, set park brake, remove ignition key and wait for all moving parts to stop before dismounting.
2. Remove the guards around belt and pulleys.
3. Remove PTO driveshaft.
4. Scribe 2 location lines at the base of each pillow block bearing. This will help to re-locate the bearings in their proper location after they are removed. Loosen lock nuts on adjustment screw, loosen bolts at the base of the pillow block bearings then loosen adjustment screw at location 2, 4 and 5 only.
5. Remove bolts from pillow block bearings 2, 4, and 5.
6. Raise #2 pillow block (note: #3 pillow block remains secure at this point), and remove belt (6) 3/3VX500 off of pulleys. Next remove input shaft assembly (bearings 4 and 5) and remove belts 3/5VX500 off of pulleys.

5.9a INSTALLING NEW BELTS

1. Reverse procedure to install new belts.
2. Install the new belt (7) around pulleys on input shaft assembly, then mount pillow blocks (4 & 5).
3. Install bolts into 2, 4, and 5 pillow blocks and lightly snug the bolts. Be sure to use the scribed lines to help in bearing and pulley alignment. Tighten adjustment screws to snug all belts.
4. Loosen 3 pillow block bolts enough so adjustments may be made for belt adjustment. Use adjustment screws at the base of the pillow blocks.
5. Go to section 5.2.1 and use belt adjustment procedure.
6. **Install all guards before operating blower unit!**

6 TROUBLE SHOOTING

The Buffalo Turbine Debris Blower uses a high volume and velocity of air to move material from one place to another. The system is simple and reliable requiring minimal maintenance.

In the following section, we have listed many of the problems, causes and solutions to the problems that you may encounter.

If you encounter a problem that is difficult to solve, even after reading through this trouble shooting section, please call your local dealer or distributor. **Before calling, please have this Operator's Manual and the serial number from your Blower ready.**

TURN OFF ENGINE, REMOVE KEY, DISCONNECT BATTERY AND REMOVE PTO SHAFT BEFORE SERVICING BLOWER UNITS. INSTALL GUARDS BEFORE OPERATING.

| PROBLEM | CAUSE | SOLUTION |
|---------------------------------------|---|---|
| Blower does not turn | PTO shaft not attached Belts slipping. Belts broken Broken coupling (Model KB2 Series) | Attach PTO shaft (Check that coupling is properly seated on input shaft) Adjust belt tension Replace belts Replace coupling |
| Belts or pulleys overheat | Belts slipping | Adjust belt tension |
| No air flow | Blower fan not turning | See solutions above |
| Reduced or no air flow | Blower fan turns | Air intake or exhaust Restricted. Shut off Engine(Model KB2 Series) Blower or tractor- Remove restrictions Debris cannot be allowed to build up between the blower fan and stationary vanes. |
| Machine vibrates Or unusual sounds | Bearing or coupling failure Out-of-balance Drive line angle too large (PTO Models) | Replace bearings or coupling Have your dealer check blower for damaged blades. Wash and clean blower fan blades Level machine |

7 SPECIFICATION

| | Model HURRICANE/PTO | Model KB2 Series |
|---------------------------|-------------------------------------|--|
| Length: | 58" with nozzle/ 38" without nozzle | Frame size 28 wide x 48 long 102" with nozzle 82" without nozzle 69" without trailer arm 48" without trailer arm and nozzle. |
| Width: | 32" | 48" with axle and tires |
| Height: | 32" | 38.5" with axle and tires |
| Weight: | 395 lbs. | 470 lbs. |
| Fuel Capacity: | | 6 gallons unleaded (Serial # 9560 to present) |
| Tires: | Built in rear roller | Turf 18 x 8.50-8 |
| Electrical System: | 12Volt with Electric Remote | 12Volt Battery/ 300 CCA |
| Input Power: | Min. 16 hp at PTO | 23 hp Kohler Engine |
| Input RPM: | Max. 540 | 3600 RPM (factory set) |
| Air Flow: | 10,000 CFM | 10,000 CFM |
| Outlet Size: | 12" | 12" |
| Outlet Velocity: | 175+MPH | 175 MPH |

SenDEC Maintenance Meter / Flash Alert -- Option for MODEL KB models.

Flash Alert is designed as a reminder to service actual maintenance. Intervals may vary by manufacturer - read your owner's manual for actual recommended service intervals.

Functions:

Hour Meter - Records actual running of engine. Non-erasable.

Tachometer - Shows engine RPMs (reads up to 9,000 RPMs).

Flash Alert - Alerts you to LUBE (grease) & CHANGE OIL (25 hour intervals).

Operation:

Fully Automatic - Upon engine start, meter will show RPMs, at engine shut down meter displays total accumulated running time.

Flash Alert Alarms will flash automatically for a 2 hour period (2 hours of engine run time) at 25 hour intervals as a service reminder.

Installation: Find a convenient mounting location, be sure the pick-up wire will reach the spark plug wire. If not, substitute with a wire of the same outside diameter of no less than 22 gauge, up to 8' long. DO NOT mount meter where surface temperature exceeds 125 degrees F. As a general guide line, if you can place your hand on the mounting surface without discomfort while equipment is at full operating temperature, then it will be suitable for mounting in that location.

Wrap pick-up wire around spark plug wire 4 to 5 times. Secure with the supplied tie-wrap.

DO NOT DRILL INTO GAS TANKS OR ENGINE CRANKCASE. If in doubt contact your dealer.

Model KB2 Parts List – BT-KB10G2

Options:

SenDec Maintenance Meter.....1372
 Fitted Waterproof Protective Cover.....BT-PC-1
 Rectangular Nozzle.....1425
 Short Rectangular Nozzle1469

| <u>Reference #</u> | <u>Quantity</u> | <u>Description</u> | <u>Part#</u> |
|--------------------|-----------------|--|--------------|
| 1 | 1 | 23 HP Kohler Engine | 1163 |
| 1A | 1 | 20 HP Honda Engine (Optional) | 1427 |
| 2 | 1 | Frame With Cradle | 1140 |
| 3 | 1 | Arm, Trailer Bolt On welded pin hitch | 1404 |
| 4 | 1 | Elbow Base, Short | 1141 |
| 5 | 2 | Fender | 1150 |
| 6 | 2 | Turf Tire and Rim Assembly | 1148 |
| 7 | 1 | Tongue Assembly | 1490 |
| 8 | 2 | Tank Straps, for fuel tank 1772 (6 gallon) | 1788 |
| 9 | 1 | Battery Box with cover | 1378 |
| 10 | 1 | Battery 300 CCA | 1132 |
| 11 | 1 | Cap, fuel tank | 1773 |
| 12 | 1 | Fuel Tank, 6 Gallon | 1772 |
| 13 | 2 | Strap, gas tank (Serial #9560 to Present) | 1788 |
| 14 | 1 | Morflex Coupling (See page 26) | 1256 |
| 15 | 1 | Nozzle, Round | 1172 |
| 16 | 2 | Elbow Segment | 1171 |
| 17 | 3 | Elbow Clamp Bands | 1173 |
| 18 | 3 | Bolt, Clamp Band | 1174 |
| 18A | 3 | Nut, Clamp Band | 1175 |
| 19 | 1 | Guard | 1159 |
| 20 | 2 | Engine Mount Brkt | 1406 |
| 21 | 1 | Blower Assembly | 1164 |
| 22 | 1 | 12V DC Rotation Motor (Bison) | 1143 |
| 23 | 1 | Motor Bracket | 1144 |
| 24 | 1 | Short Rectangular Nozzle (Optional) | 1469 |
| 25 | 1 | Belt, A54 | 1142 |
| 26 | 1 | Sheave, AK32 X ½ | 1145 |
| 27 | 3 | Thrown object decal | 1227 |
| 28 | 1 | Control Box w 12' of cable | 1567 |
| 29 | 1 | Remote Cable For Control Box | 1292 |
| 30 | 2 | Toggle Switch For Control Box | 1277 |
| 31 | 2 | Rubber Grommet For Toggle Switch | 1278 |
| 32 | 1 | Slide Actuator, 4" Standard | 1409 |
| 33 | 1 | Bellmouth | 1119 |
| 34 | 1 | Shaft Collar, 1-1/4 | 1117 |
| 35 | 2 | Slides, nylon | 1138 |
| 36 | 1 | Eye Protection Decal | 1184 |
| 37 | 1 | Ear Protection Decal | 1185 |
| 38 | 1 | 8x10 BT Decal | 1187 |
| 39 | 1 | Do Not Operate Without Guard Decal | 1186 |
| 40 | 2 | 2-1/2 x 2-1/2 BT Decal | 1232 |
| 41 | 2 | America & Safety First Decal | 1233 |
| 42 | 1 | Fuel Tank, 6 gallon Serial # 9560 to present | 1772 |
| 43 | 1 | Cap, Fuel Tank Serial # 9560 to present | 1773 |

BOLT ON TRAILER ASSEMBLY

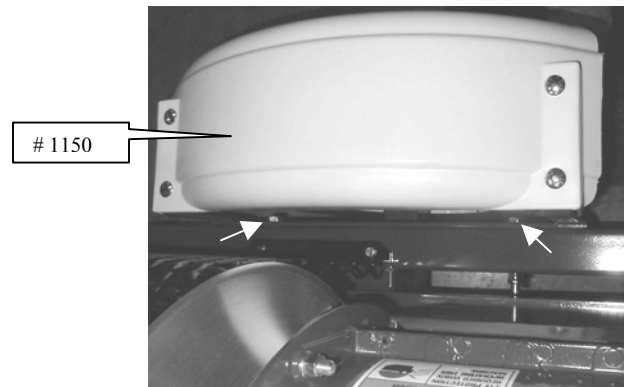
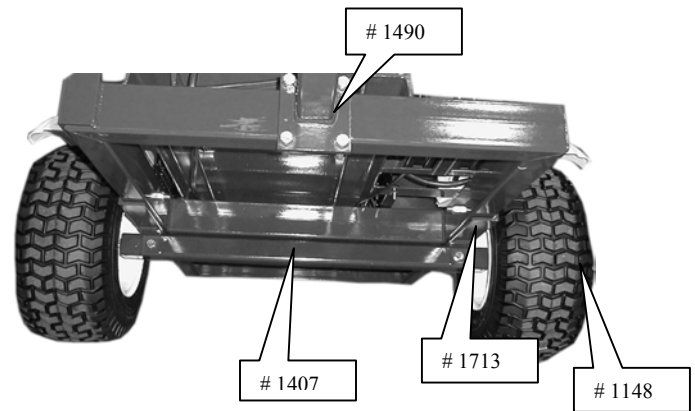
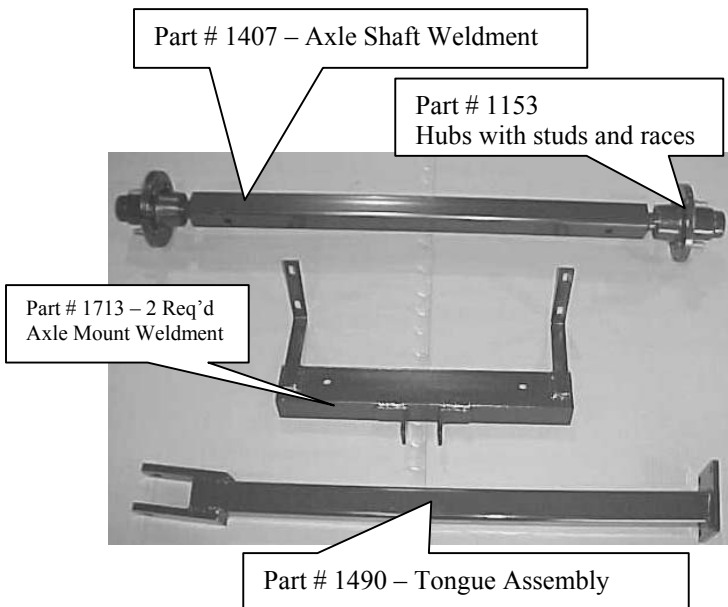

WHEEL HUB ASSY.

Part # 1153 – Hub (with races)
1690 – Bearing 2 req'd
1691 – Seal
1151 – Nut
1575 – Cap
1576 – Lug Nuts

BT-KB10G2 Assembly Instructions

1. Fill engine oil to proper level. (overseas shipments)
2. Fill battery with battery acid to proper level. (overseas shipments)
3. Attach 2 axle mounts with 2 bolts each. Do not tighten.
4. Attach axle to axle mounts using 2 bolts. Do not tighten.
5. Tighten 4 axle mount bolts then tighten the 2 bolts holding the axle.
6. Attach the tongue using the 2 U-bolts, center on the frame then tighten evenly. Equal pressure must be applied on each hex. Note: The tongue is reversible and will allow for 2 different heights. Determine the desired height before attaching the tongue.
7. Attach Fenders
8. Recheck all mounting bolts to assure that they are tight.
9. Bolt on tires.
10. Reattach positive battery cable to proper terminal.

MODEL KB2 SERIES PART LOCATIONS

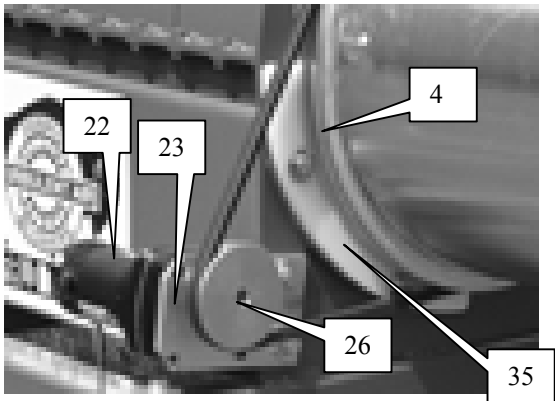

Guards removed for clarity
(CE unit only)

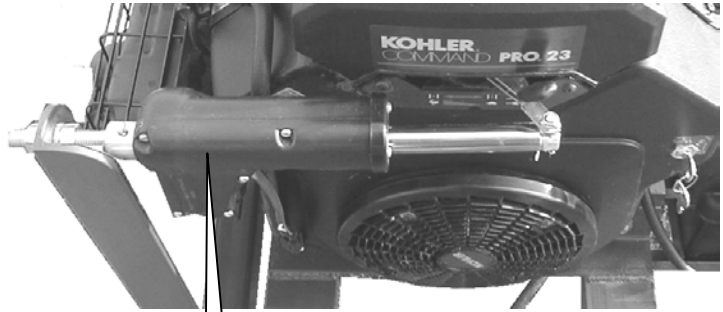

See page 24 for part
details on slide actuator



Rotation Belt Guard
Part # 1785
(CE units only)

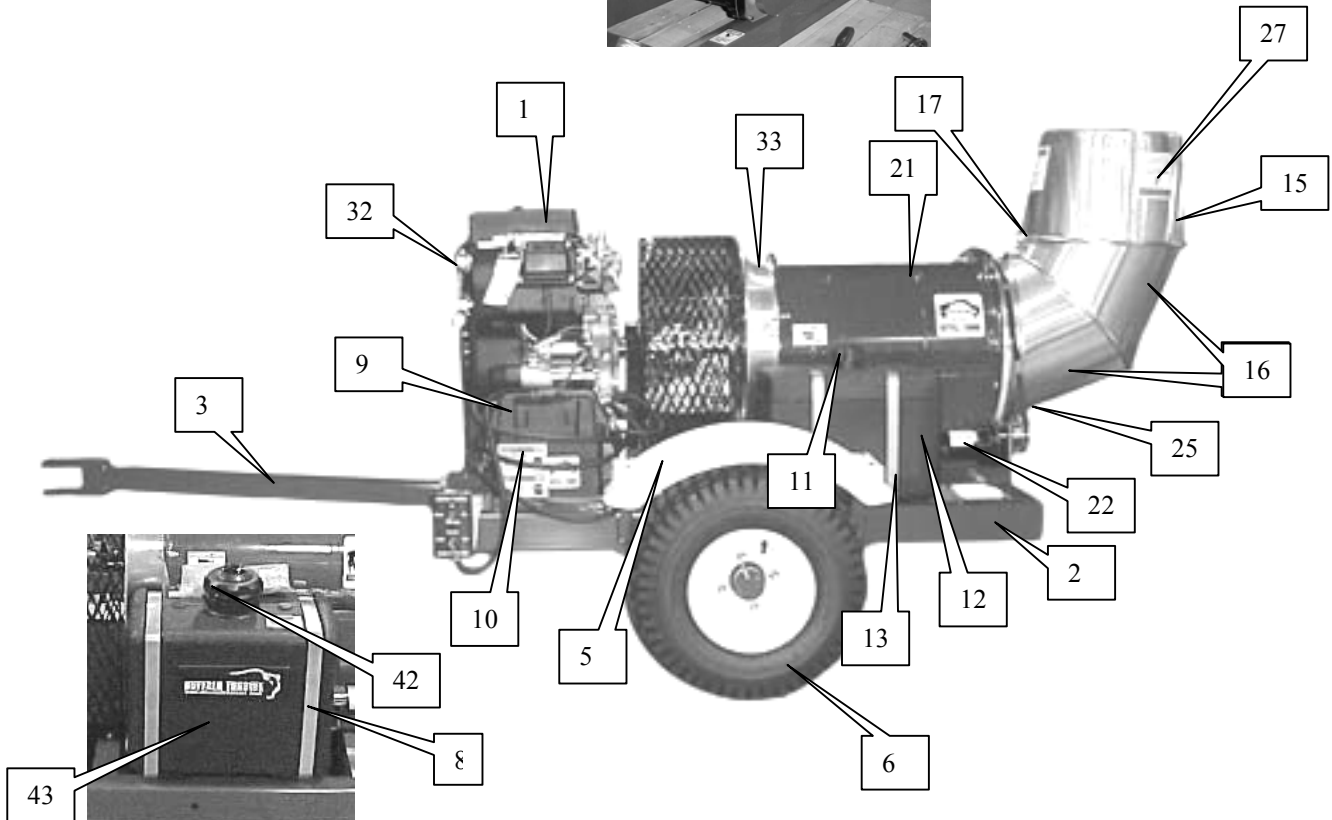

New 6-gallon tank – Serial # 9560 to present

Model KB2 Series Muffler Guards

(Used For EC Conformity Only)

Kohler Part # 28 755 29-S

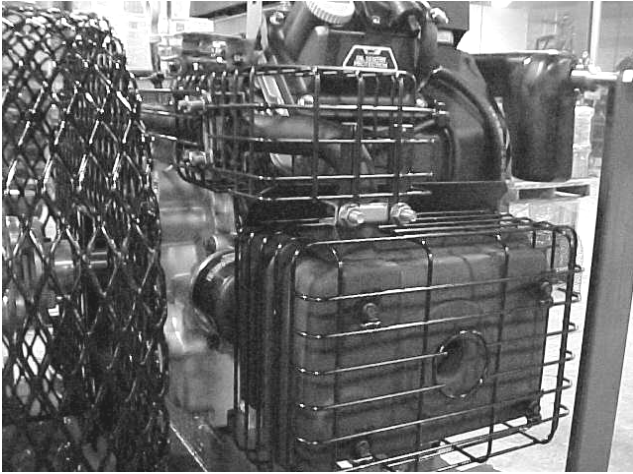

Cushman Truckster Mounting Bracket Part # 1614

Nozzle Extension
Part # 1468 - 12"



Truckster Bracket Part # 1614

INSTALLATION INSTRUCTIONS & PARTS FOR THE MOREFLEX COUPLING

PART # 1746 – COUPLING COMPLETE, KOHLER ENGINE
PART # 1747 – COUPLING COMPLETE, HONDA ENGINE

ALIGNMENT OF TURBINE SHAFT WITH SHAFT OF ENGINE IS CRITICAL

1. Install keys in both shafts.
2. Slide coupling flanges on both shafts (engine and turbine shafts)
3. Place Moreflex coupling CENTER SECTION between coupling flanges and secure with 4 bolts and TOPLOC nuts. The bolt heads are positioned against the coupling in alternating directions. Tighten all 4 bolts. DO NOT TIGHTEN SET SCREWS AT THIS TIME.
4. Check key for proper position under the set screw hole on both shafts.
5. Place a couple of drops of Loctite 271 into these two holes only. Set screws and tapped screw holes must be free of dirt and oil for Loctite to work properly.
6. Install the set screws over the keys and tighten firmly.
7. Using a drill point, dimple each shaft through the other 2 set screw holes. Clean drill chips, oil and dirt before applying Loctite.
8. Place a couple of drops of Loctite 271 in these 2 holes.
9. Install and tighten set screws in these 2 holes.
10. Check and retighten the 4 bolts that hold the coupling center section in place.
11. Visually inspect the unit and replace the guard. DO NOT OPERATE WITHOUT THE GUARDS IN PLACE.

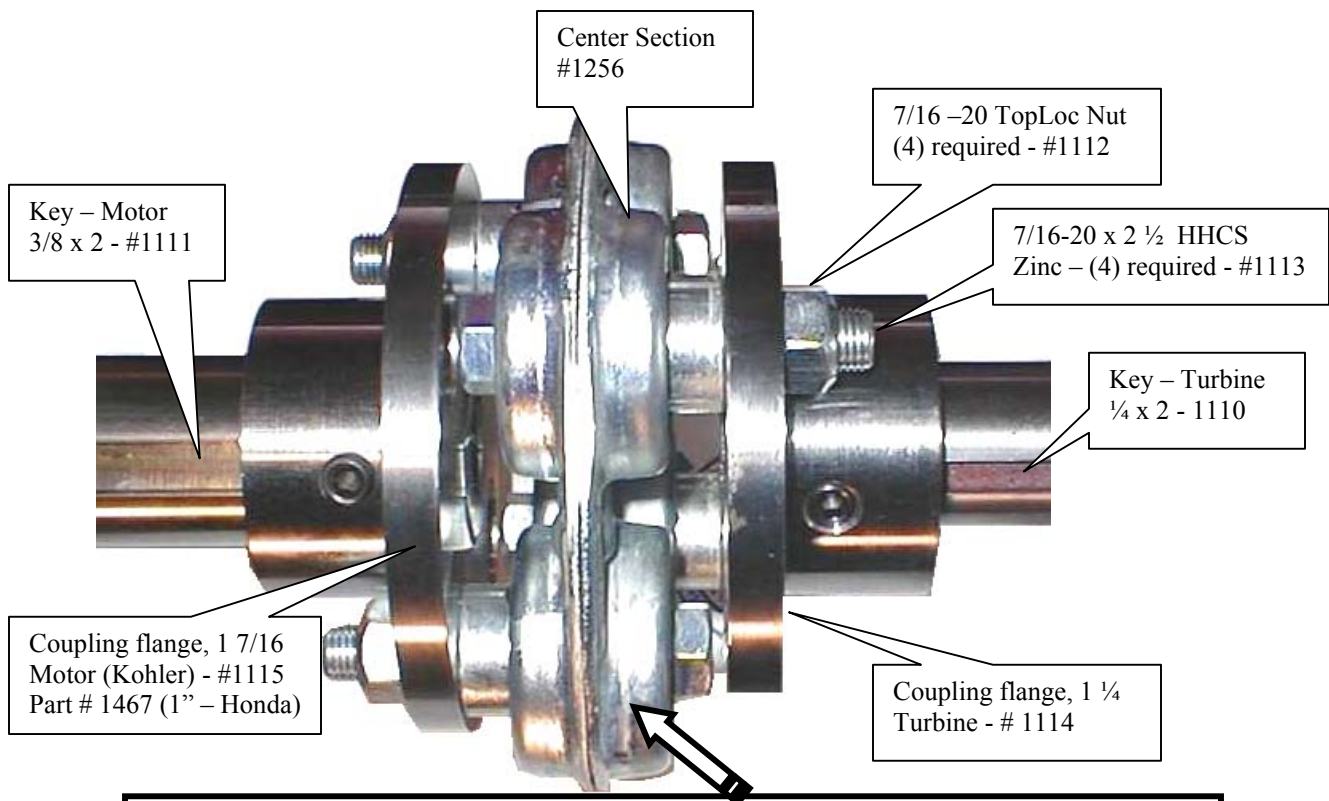

Part # 1256 (center section) is a "WEAR" item that should be visually checked each time the engine oil is changed. This coupling is equipped with special lock nuts. Occasionally check that all 4 nuts are securely fastened. LOOK FOR CRACKS IN THE RUBBER COMPOSITION THAT SURROUNDS THE 4 BUSHINGS. Replace the center section when the rubber composition begins to show signs of cracking, an increase in vibration and / or unusual sound.

CONTROL BOX ASSEMBLY

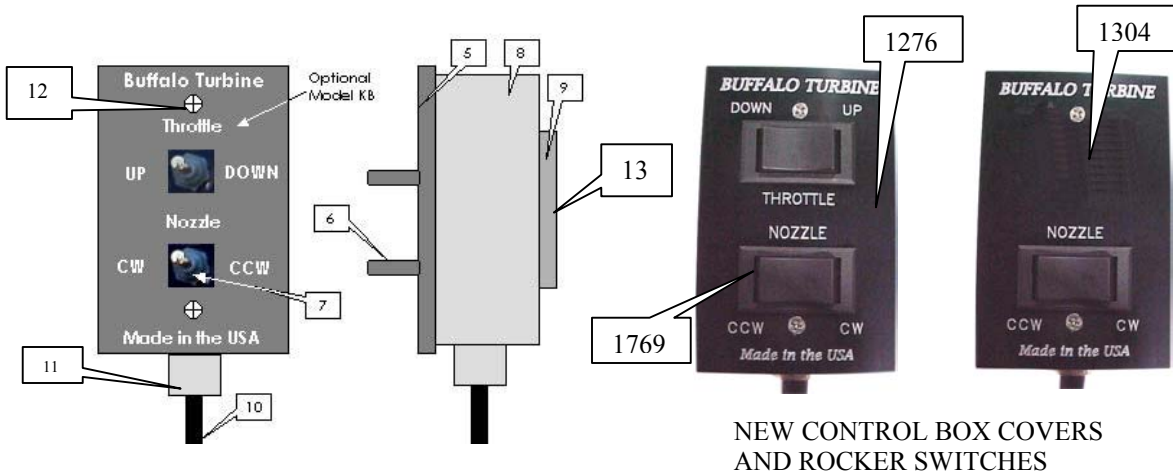

NEW CONTROL BOX COVERS
AND ROCKER SWITCHES

| Ref # | Part # | Description |
|-------|--------|---|
| 5 | 1276 | Throttle / Nozzle Cover |
| 6 | 1277 | Toggle Switch (2) 1769 (rocker switch) |
| 7 | 1278 | Rubber Switch Cover |
| 8 | 1281 | Control Box Housing |
| 9 | 1300 | Magnet |
| 10 | 1292 | 18/6 Wire, 144" |
| 11 | 1289 | Wire Nut |
| | 1360 | Control Box Assy w/ 144" Cable (KB Nozzle Control Only) |
| | 1265 | Control Box Assy w/ 144" Cable (3 point hitch & Front Mounts) |
| | 1567 | Control Box Assy w/ 144" Cable (KB Nozzle & Throttle Control) |
| 12 | 1310 | 6-32 x 1" Phillip head screws |
| 13 | 1258 | 1/4-20 x 3/4 screw to attach magnet to control box |

Slide Actuator (Kohler Engine)

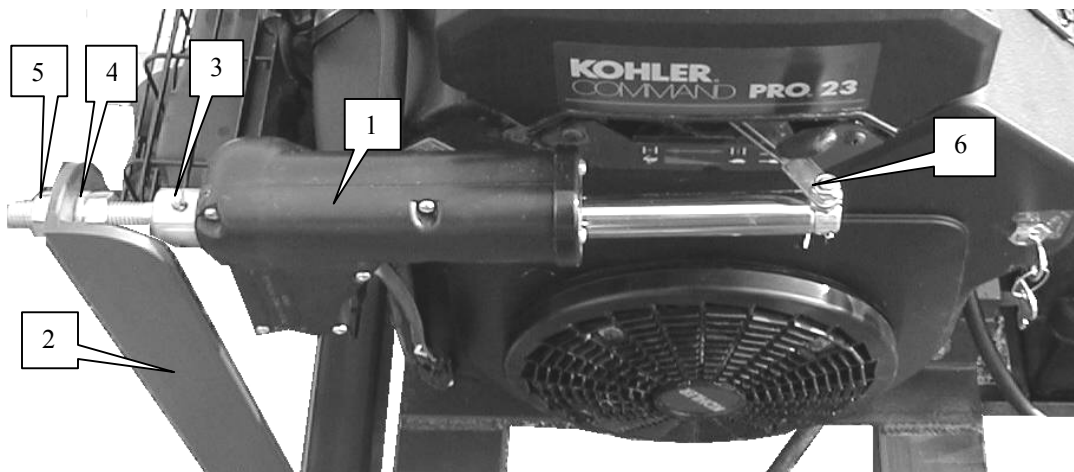

| Ref # | Description | Part # |
|-------|------------------------------|------------------------|
| 1 | Slide Actuator, 4" Stroke | 1409 |
| 2 | Angle Brkt Mount | Misc. (frame weldment) |
| 3 | Actuator Mount | 1451 |
| 4 | 1/2 Lock Washer, Zinc Plated | 1222 |
| 5 | 1/2 -13 Hex Nut, Zinc Plated | 1231 |
| 6 | KB Remote Throttle Pin | 1414 |

MOUNTING BLOWER ASSEMBLY ONTO FRAME
AND ALIGNMENT RECOMMENDATIONS

1. Install blower assembly onto frame and tighten all of the bolts.
2. Remove all burrs and oil from the shafts and keyways (engine and blower shafts).
3. Using the supplied gauge, align the shafts parallel to each other (very important).
4. Check in four places around the shafts at 90° to each other.
5. When properly aligned, gauge should have little to no gap between itself and the shafts at any point along the gauge.
6. To adjust, move the engine. The 2 mounting brackets have tapped holes in each corner to help support and adjust the position of the engine. The 4 roll pins may need to be repositioned after alignment is completed and bolts are tightened.
7. Tighten all engine bolts and recheck alignment. Drill and install 4 roll pins in new position.

ACCEPTABLE

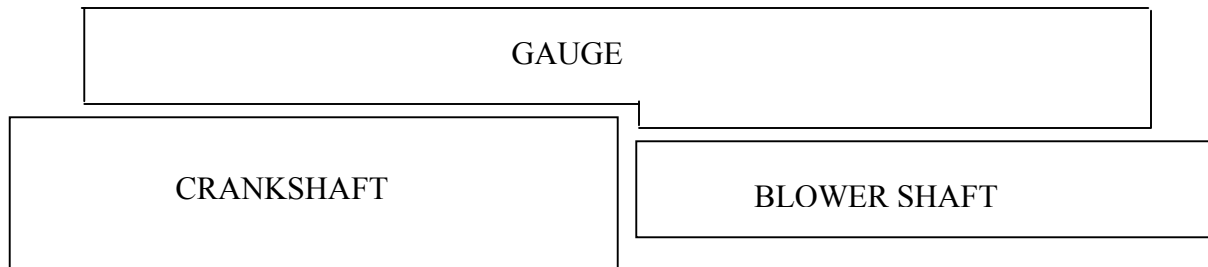

NOT ACCEPTABLE

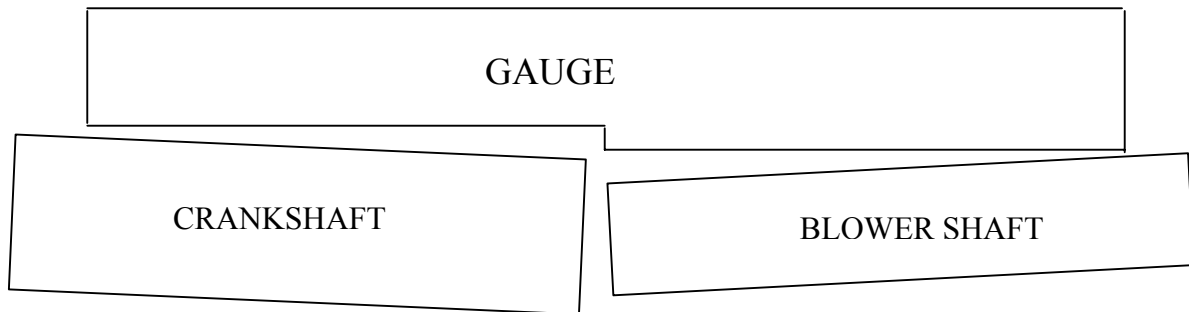

SECURELY ATTACH GUARDS BEFORE OPERATING BLOWER UNITS

Model Hurricane Parts List- BT-HPTO10G

Options:

| | |
|-------------------------------------|---------|
| Support Stand | 1471 |
| Fitted Waterproof Protective Cover | BT-PC-1 |
| Rectangular Nozzle (19" long) | 1425 |
| Short Rectangular Nozzle (10" long) | 1469 |
| Grease Gun Extension | 1470 |

| Reference # | Quantity | Description | Part # |
|-------------|----------|---|--------|
| 1 | 1 | Main Frame Hurricane | 1388 |
| 2 | 2 | Lift Pins | 1198 |
| 3 | 1 | Guard | 1389 |
| 4 | 1 | Guard, Front | 1200 |
| 5 | 1 | Bearing Mount | 1201 |
| 6 | 1 | Flange Mount Bearing 1 ¼ | 1262 |
| 7 | 2 | Elbow Segment | 1171 |
| 8 | 1 | Round Nozzle, 12" | 1172 |
| 9 | 1 | Elbow Base, Short | 1141 |
| 10 | 3 | Clamp Band | 1173 |
| 12 | 1 | Rotation Motor | 1143 |
| 13 | 1 | Round Nozzle, 10" (Optional) | 1417 |
| 14 | 1 | Motor Bracket | 1144 |
| 15 | 1 | Belt, A-52 (Optional) | 1241 |
| 15A | 1 | Belt, A-54 (Standard) | 1142 |
| 16 | 1 | Sheave AK32x1/2 (Standard) | 1145 |
| 17 | 4 | Pillow Block, Bearing 1 7/16 | 1204 |
| 18 | 1 | Shaft, Input (Splined) (Serial # 8504 to present) | 1253 |
| 19 | 1 | Shaft, Jack | 1386 |
| 20 | 1 | Shaft PTO | 1553 |
| 21 | 1 | Top Pin, Upper | 1208 |
| 22 | 1 | Belt, 3/3VX500 Power Band | 1255 |
| 23 | 1 | Belt, 3/5VX500-(Serial #5122,5124- Present) | 1210 |
| 24 | 1 | Sheave, 3/3V10.60SK-(Serial # 5080-Present) | 1235 |
| 24A | 1 | Sheave, 3-5V12.5E | 1211 |
| 25 | 1 | Sheave, 3/5V5.5 SDS (Serial # 5080-Present) | 1238 |
| 26 | 1 | Sheave, 3GR3V3.65-(Serial # 5080-Present) | 1212 |
| 27 | 1 | Bushing, SK 1 7/16 | 1213 |
| 27A | 1 | Bushing, E 1-7/16-(For 1211) | 1214 |
| 28 | 1 | Bushing, SDS 1 7/16 | 1215 |
| 29 | 1 | Bushing, SH 11/4 | 1216 |
| 30 | 4 | Bolt, ½ Pushover | 1218 |
| 31 | 1 | Blower Assembly | 1390 |
| 32 | 1 | Shaft Collar, 1-1/4 | 1117 |
| 33 | 1 | Wheel, Hand (Optional) | 1246 |
| 34 | 1 | Sheave, 4.1 x ¾ (Optional) | 1251 |
| 35 | 2 | Collar, Shaft ¾ (Optional) | 1250 |
| 36 | 1 | Bearing, Pillow Locking (Optional) | 1248 |
| 37 | 1 | Bearing, ¾ Pillow Block (Optional) | 1247 |
| 38 | 8 | Nut Plate, ½ | 1219 |
| 39 | 6 | Spacer, 3/16 X 1 | 1106 |
| 40 | | | |
| 41 | | | |
| 42 | 1 | Retaining washer, 3/8 x 1-5/8 | 1220 |

| | | | |
|-----|----|--|------|
| 43 | 10 | ¼ Self Tapping Screws | 1116 |
| 44 | 8 | ½"- 20 X 2" HHCS Pillow Block Bolts | 1221 |
| 45 | 12 | ½" Lock Washers, Pillow Block | 1222 |
| 46 | 10 | ½" X 3/16" Thick Washers Pillow Block | 1223 |
| 47 | 4 | ½"-13 X 2" HHCS Blower Bearing Bracket | 1224 |
| 48 | 18 | 3/8" – 24 X 1-1/2" HHCS | 1101 |
| 49 | 7 | 3/8" – 24 X 1-1/4" HHCS | 1100 |
| 50 | 14 | 3/8" Flat Washer | 1108 |
| 51 | | | |
| 52 | 3 | Lynch Pin | 1225 |
| 53 | 4 | ½" Flat Washer | 1226 |
| 54 | 6 | 3/16" Roll Pin | 1236 |
| 55 | 1 | Spinner | 1118 |
| 56 | 1 | Bellmouth | 1119 |
| 57 | 2 | Plastic Slides | 1138 |
| 58 | 5 | 45 Degree Grease Fitting | 1217 |
| 59 | 4 | 3/8 Notched Washer | 1139 |
| 60 | 3 | ¼- 20 X 2-1/4 Stove Bolt | 1174 |
| 61 | 5 | ¼- 20 Square Nut | 1175 |
| 62 | 3 | 5/16-18 X ¼ Set Screw | 1130 |
| 63 | 1 | Serial Tag | 1156 |
| 64 | 4 | Drive Pin For Serial Tag | 1157 |
| 65 | 2 | 3/8-24 X 2 HHCS Zinc | 1104 |
| 66 | 1 | 3/8-24 X 2 Faced Head Screw | 1103 |
| 67 | | | |
| 68 | 2 | ½-13 Hex Nut | 1231 |
| 69 | 15 | 3/8-24 Hex Nut | 1105 |
| 70 | 4 | 3/8 Nylon Nut (Optional) | 1242 |
| 71 | 1 | Hand Wheel Support (Optional) | 1243 |
| 72 | 2 | 3/8 X 4-1/2 Allen Cap Screw (Optional) | 1244 |
| 73 | 2 | 3/8 X 2-1/2 Allen Cap Screw (Optional) | 1245 |
| 74 | 1 | Shaft, Nozzle Turning 58" (Optional) | 1249 |
| 75 | 2 | ¼-20 X 1 HHCS (Standard) | 1169 |
| 76 | 4 | 5/16 x ¼ Covered Wire Clamp (Standard) | 1167 |
| 76A | 1 | Control Box (Standard) See Control Box Page 28 | 1265 |
| 76B | 1 | Rocker Switch For Control Box (Standard) | 1277 |
| 76C | 1 | Rubber Grommet For Toggle Switch (Standard) | 1278 |
| 76D | 1 | Remote Cable For Control Box (Standard) | 1305 |
| 77 | 3 | Thrown Object Decal | 1227 |
| 78 | 1 | 4 X 4 BT Decal | 1182 |
| 79 | 1 | Ear Protection Decal | 1185 |
| 80 | 1 | Eye Protection Decal | 1184 |
| 81 | 3 | Rotating Drive Hazard Decal | 1228 |
| 82 | 1 | Keep Hands Clear Decal | 1229 |
| 83 | 2 | 8 X 10 BT Decal | 1187 |
| 84 | 1 | Do Not Operate without Guard Decal | 1186 |
| 85 | 2 | 2-1/2 X 2-1/2 BT Decal | 1232 |
| 86 | 2 | America & Safety First Decal | 1233 |
| 87 | 1 | Rear Roller with end caps | 1374 |
| 88 | 1 | Mounting Shaft (rear roller) | 1375 |
| 89 | 1 | Shaft Collar, 1-1/4 | 1117 |

Hurricane/PTO parts reference

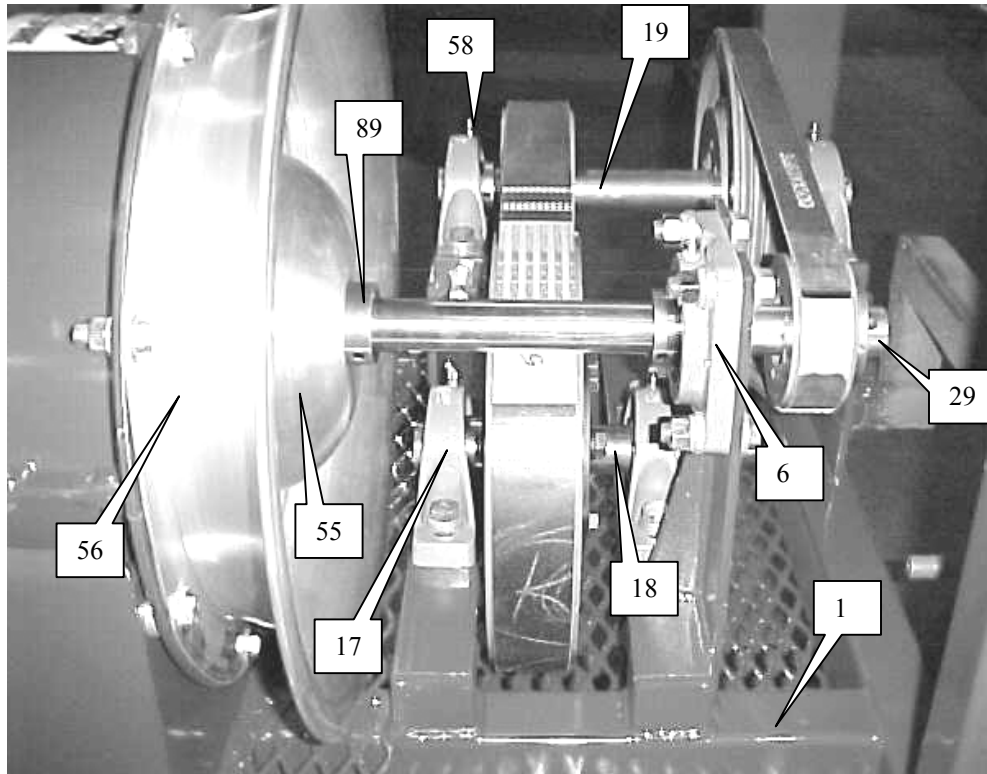

GUARDS REMOVED FOR CLARITY

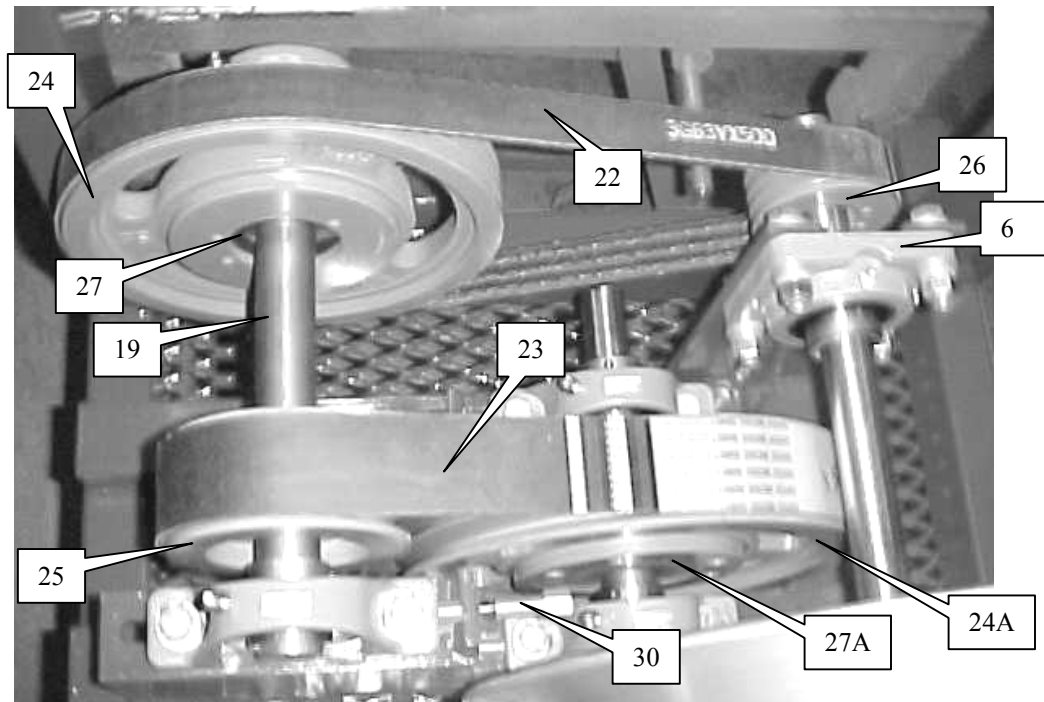

Hurricane PTO Shaft -- 1553

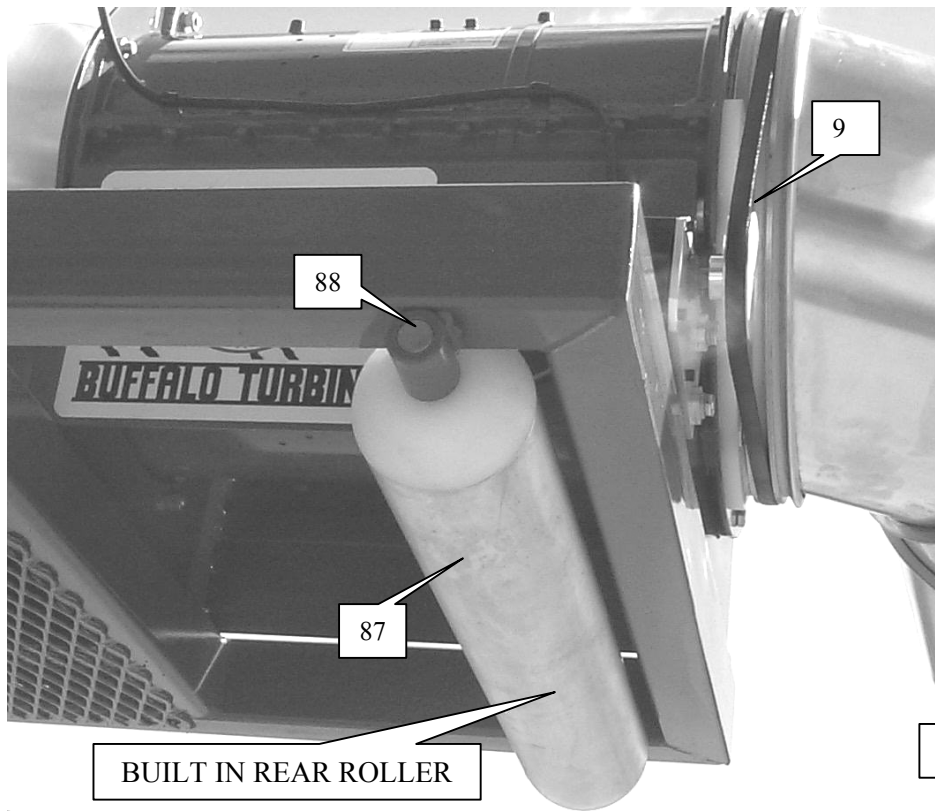

Bottom View of Hurricane/PTO



Rotation Belt Guard Part # 1785

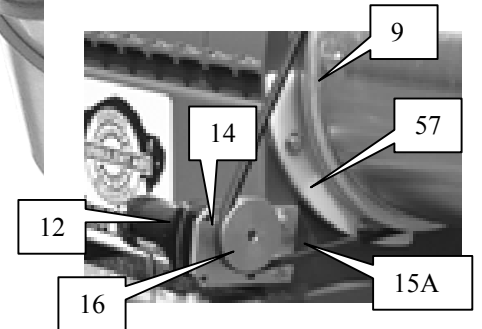

GUARD REMOVED FOR CLARITY (CE Units Only)

Hurricane/PTO Parts Reference

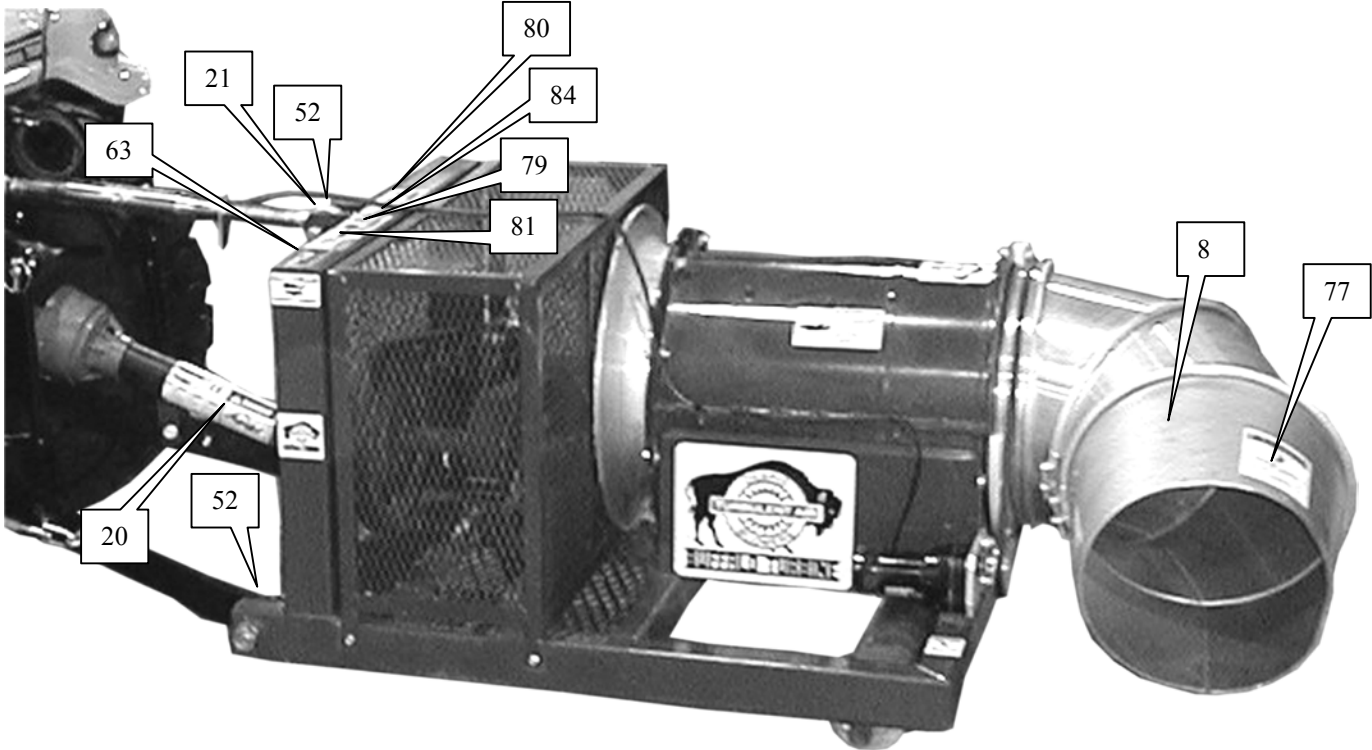

GUARDS REMOVED FOR CLARITY

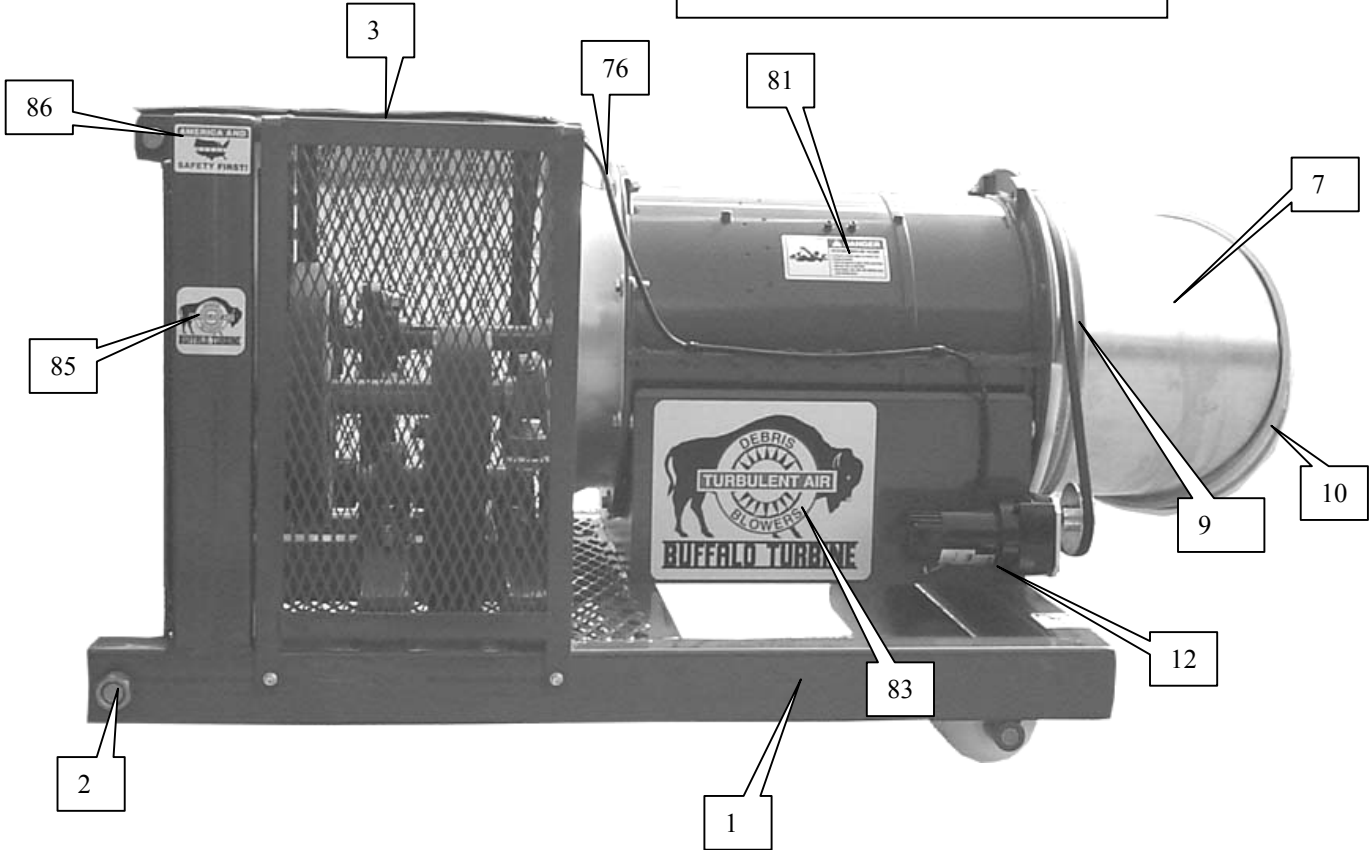

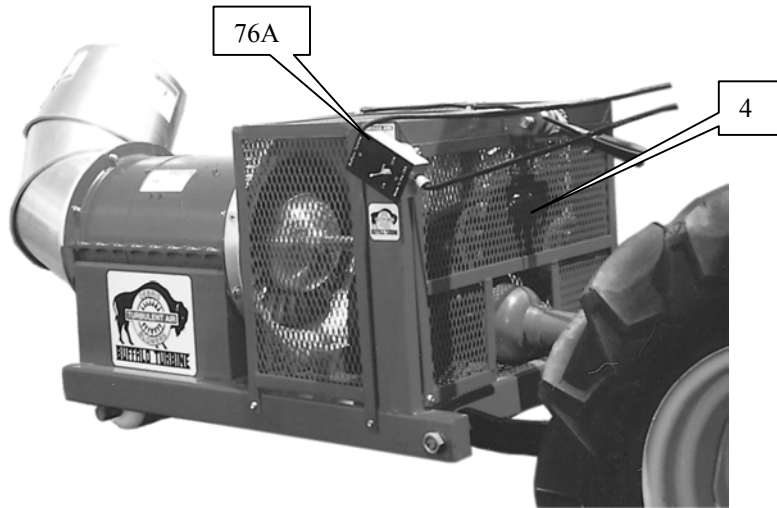

Wiring Diagram for the Model KB & Hurricane/PTO Remote Nozzle and Throttle Kit

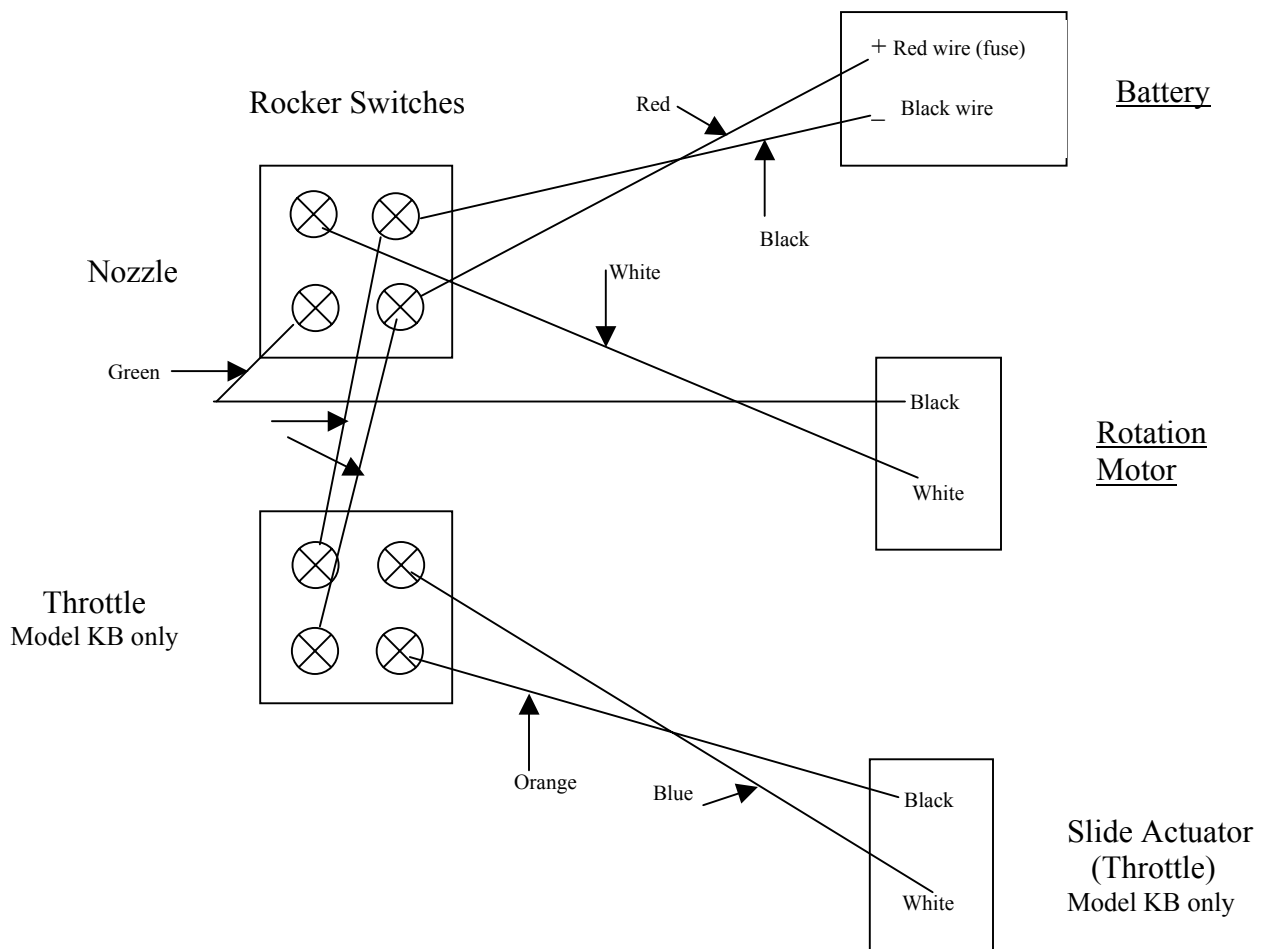

For the Hurricane/PTO: Check wiring using the nozzle toggle switch diagram only.
The power connection will be to the tractor's 12- volt system.



Buffalo Turbine LLC

BuffaloTurbine LLC
180 Zoar Road
Springville, NY 14141
Tel: 716-592-2700 Fax: 716-592-2460
info@buffaloturbine.com
www.buffaloturbine.com

Debris Blowers, Greens Fans, Sprayers, Dusters and Top Dressers **EC Declaration of Conformity**

We, Buffalo Turbine Agricultural Equipment Company Inc. of Gowanda New York, USA

Declare that:

Debris blowers, Models KB2 and Hurricane PTO

In accordance with the following directives:

Machinery Directive 98/37/EC and it's amending directives

Noise in the Environment Directive 2000/14/EC and it's amending directives

Has been designed and manufactured to the following specifications:

ISO 11094:1991

With a guaranteed sound power level of:

Lwa 120dB

Buffalo Turbine certifies that the equipment named above has been designed to comply with the relevant sections of the above referenced specifications. The units comply with all essential requirements of these directives.



Part # 1783



Part # 1784

ATTENTION ALL BUFFALO TURBINE PRODUCT USERS,
DEALERS, DISTRIBUTORS, SERVICE AND EQUIPMENT
MANAGERS, AND MAINTENANCE PERSONNEL.

ANY ENGINE SERVICE, ENGINE PARTS OR ENGINE
WARRANTY CONCERNS, CONTACT YOUR LOCAL KOHLER
OR HONDA REPRESENTATIVE.

REPAIR PARTS MUST BE ORDERED THROUGH YOUR
BUFFALO TURBINE DEALER.

PLEASE CONTACT ERIC (BUFFALO TURBINE'S SERVICE
DEPARTMENT MANAGER) AT 716 592 5000 FOR ANY
SERVICE QUESTION YOU MAY HAVE REGARDING THE
BUFFALO TURBINE BLOWERS OR SPRAYERS.

THANK YOU FOR YOUR COOPERATION.